



Mac Chain Co. Ltd.

800-663-0072
[UNITED STATES]

800-663-0072
[WESTERN CANADA]

877-833-1653
[EASTERN CANADA]

WR82XHD-15

MILL CHAIN SPROCKETS > WR82XHD Sprocket

Mac Mill Chain Sprockets are generally Flame Cut from mild steel plate or the recommended QT400 hardened plate.

- Machined or precision hobbed sprockets are also available for high speed applications
- Split to bolt or split for welding sprockets are available for difficult mounting or dismounting applications
- Mac Chain can supply brass, nylon or UHMW bushed Idlers complete with grease grooves and grease fittings

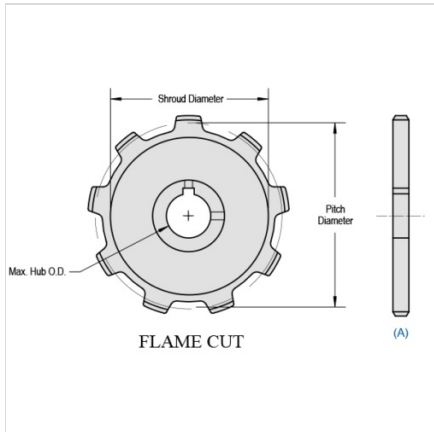

Part Number	Average Pitch	Number of Teeth	Pin Style	Pitch Diameter	Max. Bore	Shroud Diameter
WR82XHD-15	3.075	15	A,B,C	14.79	5 15/16	13.200
Part Number	Tooth Face					
WR82XHD-15	1 1/8"					

Questions about ordering? Call us!

WE'RE HERE TO HELP!

www.macchain.com
ussales@macchain.com

